



# Jackson Place, Great Baddow, Chelmsford, CM2 9SF

Council Tax Band C (Chelmsford City Council)

 1  2  1

£350,000 Freehold

Bond Residential are delighted to offer for sale this semi detached bungalow being sold with no onward chain situated in the popular Great Baddow area.

The property offers an entrance hall, lounge/diner, fitted kitchen, two bedrooms and a shower room with modern white suite. Outside the property benefits from a driveway to the side of the bungalow which provides off road parking and in turn leads to the garage. The mature rear garden is mainly laid lawn with established flowers & shrubs to borders.

## LOCATION

Jackson Place is situated in a pleasant cul-de-sac off Duffield Road in the sought after Great Baddow area located on the highly desirable South side of Chelmsford.

There are local amenities and shops within close proximity of the property and a regular bus service which provides access into Chelmsford city centre. The city centre offers a fantastic range of places to socialise and eat with a wide range of restaurants from small family run independent ones to larger well know chains serving cuisines from around the world. Along with a thriving nightlife with a selection of bars, there are two theatres including the Civic Theatre and two multi-screen cinemas. The pedestrianised High Street, two shopping precincts, retail parks as well as several designer stores in the popular Bond Street ensure residents benefit from a wide choice of shopping facilities.

Chelmsford offers a comprehensive range of leisure and sporting facilities with a selection of gyms, the newly refurbished Riverside Ice & Leisure Centre, a selection of sports clubs can be found in the Great Baddow area at both Chelmer Park and Baddow Recreational Ground.

Chelmsford is renowned for its educational excellence and, alongside the local schools, it offers two of the country's top performing grammar schools, Writtle Agricultural College, Anglia Ruskin University, and several private schools.

Chelmsford is a sought-after commuting city with a mainline station offering a direct service to London Liverpool St with a journey time as fast as 38 minutes. Jackson Place is conveniently positioned within easy access of the A12.

- Semi Detached Bungalow
- Gas Central Heating
- Lounge/Diner
- Shower Room
- Mature Rear Garden

- No Onward Chain
- Two Bedrooms
- Fitted Kitchen
- Garage & Driveway

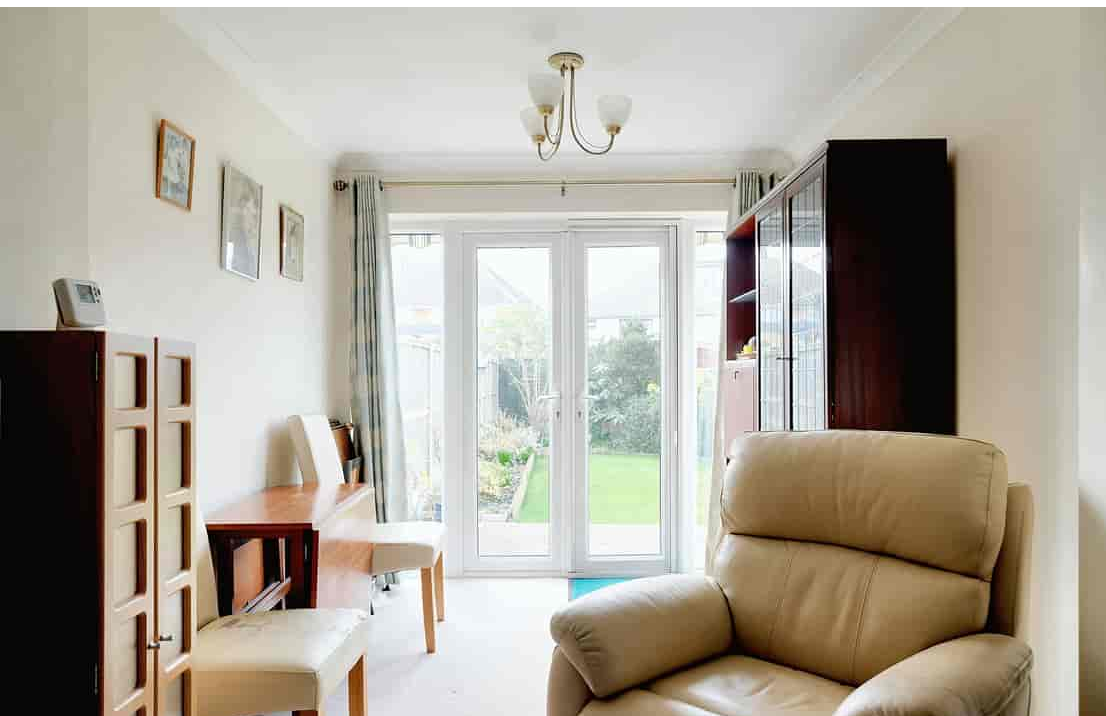

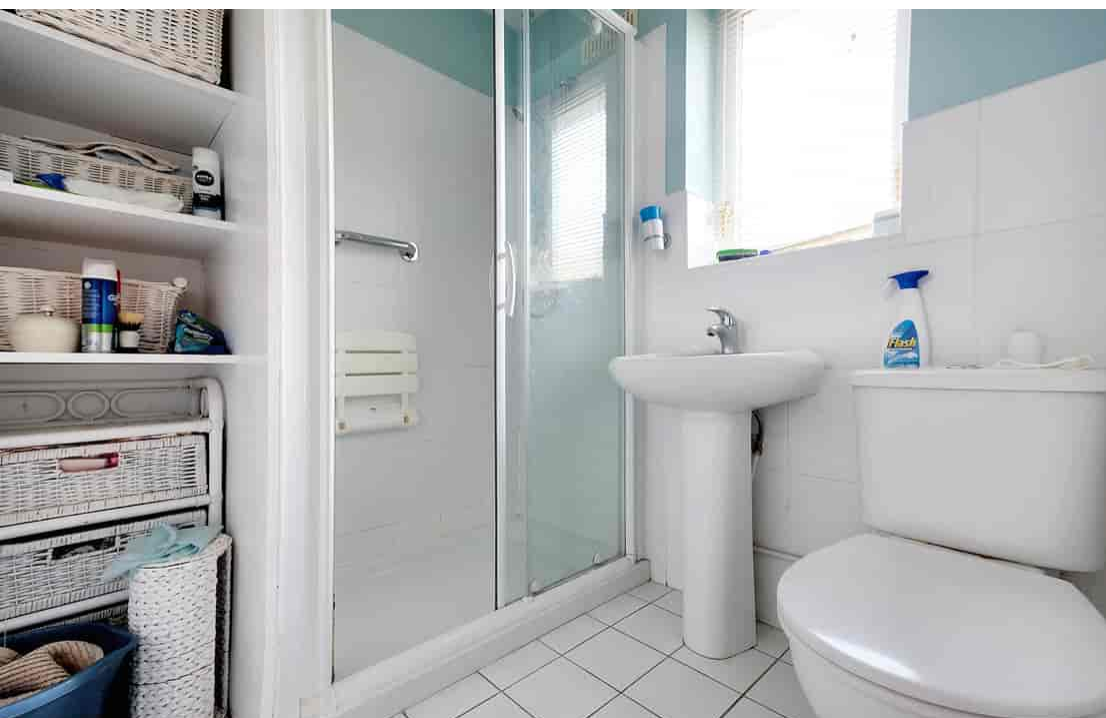



## Ground Floor

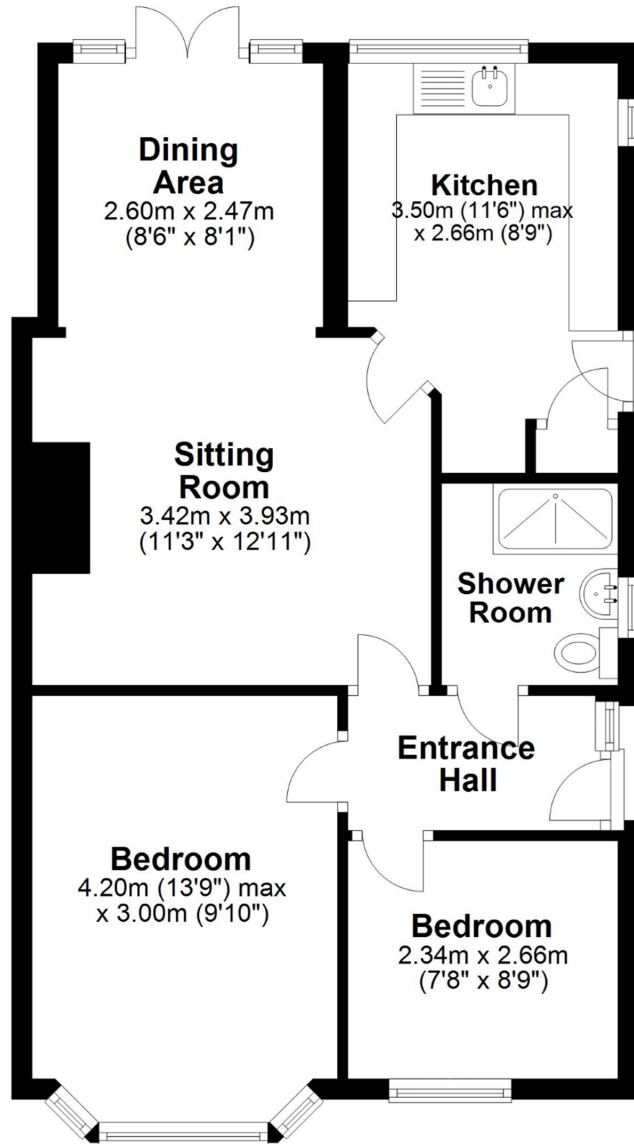

## Outbuilding

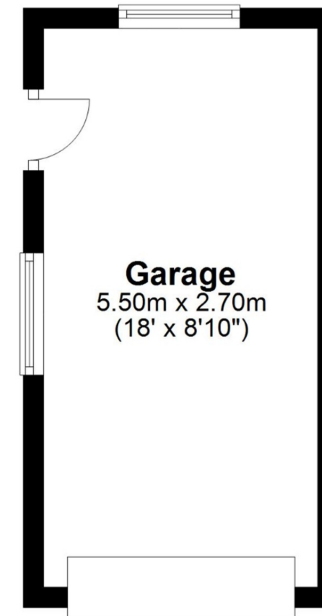

**APPROX INTERNAL FLOOR AREA 57 SQ M (620 SQ FT)**  
**OUTBUILDING 15 SQ M (160 SQ FT)**

This floorplan is for illustrative purposes only and is **NOT TO SCALE**  
All measurements are approximate **NOT** to be used for valuation purposes.  
**Copyright Bond Residential 2024**

78, New London Road,  
Chelmsford, Essex, CM2 0PD  
Telephone: 01245 500599  
Website: [www.bondresidential.co.uk](http://www.bondresidential.co.uk)

Consumer Protection from Unfair Trading Regulations 2008 and the Business Protection from Misleading Marketing Regulations 2008. Bond Residential have made every effort to ensure that consumers and/or businesses are treated fairly and provided with accurate material information as required by law. We have not tested any apparatus, equipment, fixture, fitting or any services and as such are unable to verify they are in working order, fit for their purpose, or within the ownership of the seller or landlord. Neither have we been able to check the legal documentation to verify the legal status of the property. We therefore advise potential buyers or tenants to verify these matters with their own solicitors or other advisers.

