

La Hauteur Lodge, La Rue Freule, St Ouen, Jersey, Channel
Islands. JE3 2EB

£680,000 Freehold

FOR SALE



PROPERTY DESCRIPTION

Welcome to this beautifully presented 3 bedroom house, situated in rural St Ouen surrounded by greenery. Down a quiet lane, just a short distance from the beach, this property offers a peaceful yet enjoyable location. Internally the living room is bright and spacious, partnered alongside a modern, recently refurbished kitchen. To the first floor are 3 double bedrooms and a house bathroom. Furthermore, this property also has easy access into the well insulated loft with plenty of scope to extend and add a master bedroom with en-suite (subject to planning permission). Externally the house boasts a small, easy to maintain, front east facing garden with parking for 1 car. Priced within the new first time buyer assistance scheme for 3 beds, potential to extend and in great condition, this great home should be high on anyone's list for viewing. Sole agent.

FEATURES

- Situated in rural St Ouen
- Beautifully presented
- Ideal for first time buyers
- Capacity to grow with the family
- 3 bedroom family home
- Close to the beach



ROOM DESCRIPTIONS







FLOORPLAN

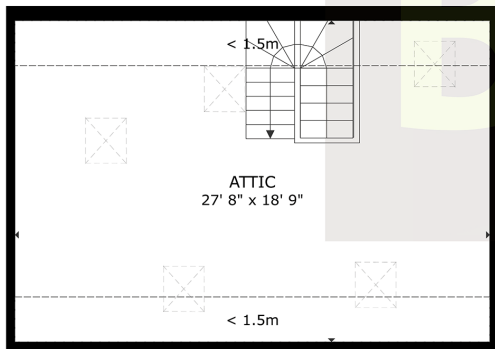
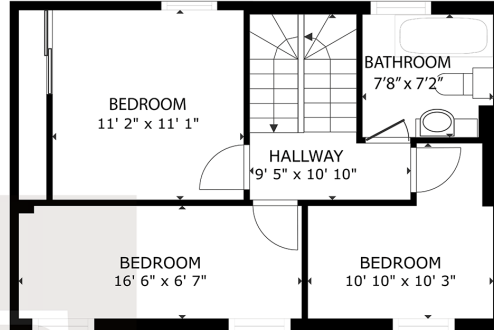
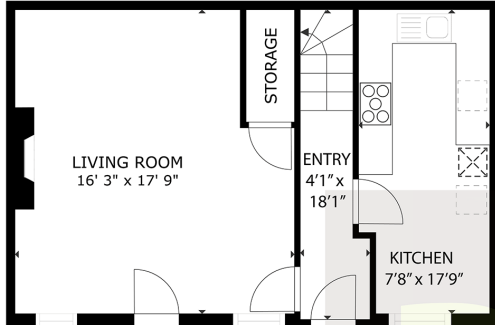

GROSS INTERNAL AREA
GROUND FLOOR: 491 sq. ft, FIRST FLOOR: 494 sq. ft, SECOND FLOOR: 372 sq. ft
TOTAL: 1357 sq. ft

EXCLUDED AREAS: REDUCED HEADROOM BELOW 1.5M: 145 sq. ft

SIZES AND DIMENSIONS ARE APPROXIMATE, ACTUAL MAY VARY