



**Thorntons**  
The right way to move

11 St Andrews  
Road,

Crail, Anstruther, Fife, KY10 3UQ





## Summary

This imposing three-bedroom end-terrace property, with enclosed gardens and unrestricted on-street parking, is located in desirable Crail, a picturesque coastal village well-served by everyday amenities. Behind the inviting stone façade lies a comfortable family home that enjoys south-facing living areas and suitably classical décor offset by charming period features. Also featured is a large utility room with a WC, a bathroom, space for home working, stair access to a floored attic, and several garden stores.

Extras: All fitted floor coverings, select window coverings, and select light fittings will be included. Additional furnishings and fittings are available by separate negotiation.

## Features

- Sought-after coastal village
- End-terrace house with inspiring interiors
- Practical vestibule and bright hall
- Generous south-facing living room
- Bespoke kitchen with a sunny dining area
- Three double bedrooms (one with a large dressing room/study)
- Bright bathroom
- Sizable ground-floor utility room with WC and front access
- Stair access to a floored attic
- Easy-to-maintain walled gardens with storage
- On-street parking
- Gas central heating



“This convivial family home enjoys well-proportioned rooms, light-filled living areas, and abundant period charm.”

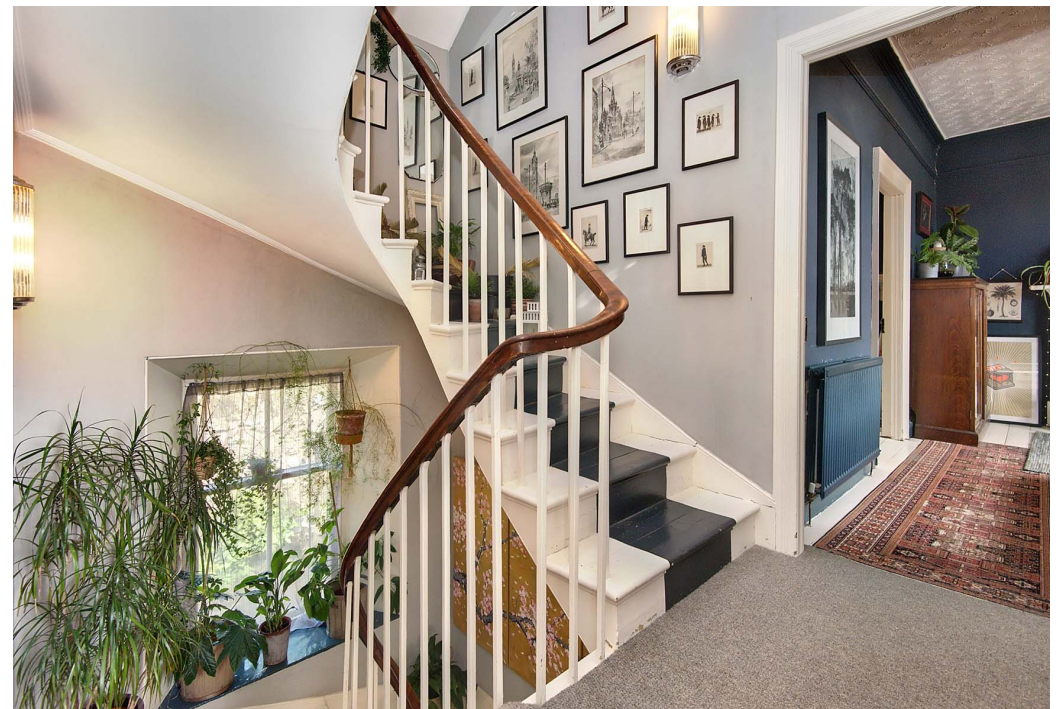





“The delightful walled gardens boast attractive front planting, a secluded rear terrace, and useful external storage.”



# Floorplan

**Garden Stores**  
Approx. 11.3 sq. metres (121.6 sq. feet)

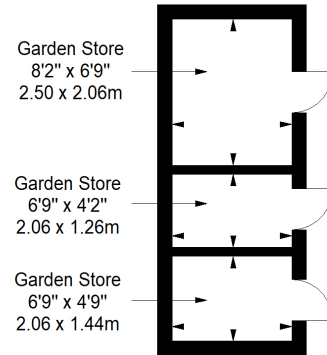

**Attic**  
Approx. 42.7 sq. metres (459.6 sq. feet)

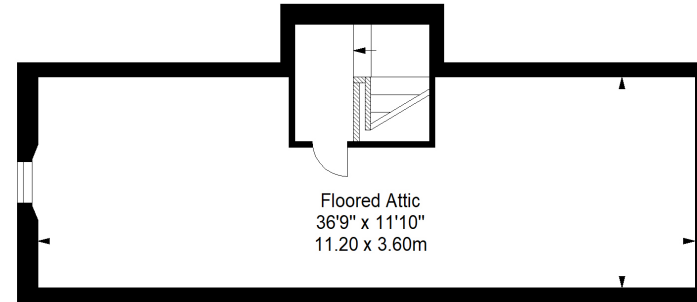

**Ground Floor**  
Approx. 81.7 sq. metres (879.5 sq. feet)

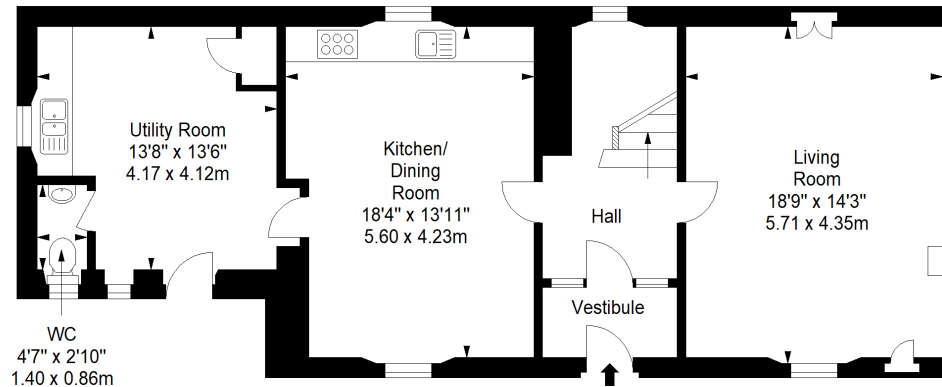

**First Floor**  
Approx. 64.5 sq. metres (694.3 sq. feet)

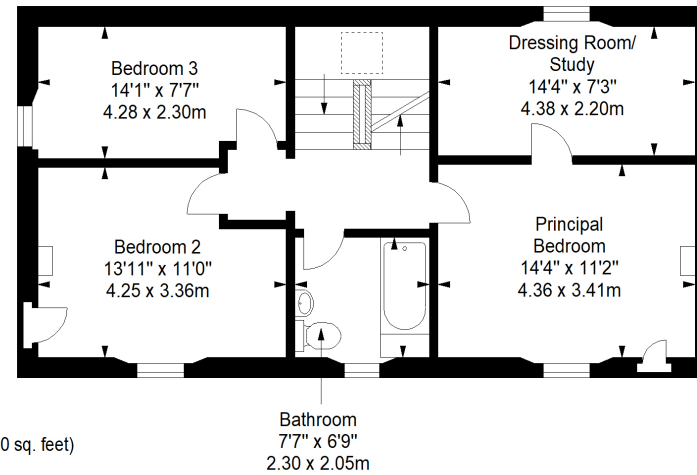

Total area: approx. 200.2 sq. metres (2155.0 sq. feet)



# Thorntons

The right way to move

## Our Branches

### ANSTRUTHER

5A Shore Street, Anstruther, KY10 3EA  
01333 310481  
anstruthearea@thorntons-law.co.uk

### BONNYRIGG

3-7 High Street, Bonnyrigg, EH19 2DA  
0131 663 7135  
bonnyriggea@thorntons-law.co.uk

### DUNDEE

Whitehall House, 33 Yeaman Shore  
Dundee DD1 4BJ  
01382 200099  
dundeesea@thorntons-law.co.uk

### FORFAR

53 East High Street, Forfar, DD8 2EL  
01307 466886  
forfarea@thorntons-law.co.uk

### PERTH

7 Whitefriars Crescent, Perth, PH2 0PA  
01738 443456  
perthea@thorntons-law.co.uk

### ARBROATH

165 High Street, Arbroath, DD1 1DR  
01241 876633  
arbroathea@thorntons-law.co.uk

### CUPAR

49 Bonnygate, Cupar, KY15 4BY  
01334 656564  
cupareaa@thorntons-law.co.uk

### EDINBURGH

Citypoint, 3rd Floor, 65 Haymarket  
Terrace, Edinburgh, EH12 5HD  
0131 297 5980  
edinburgea@thorntons-law.co.uk

### MONTROSE

55 High Street, Montrose, DD10 8LR  
01674 673444  
montroseea@thorntons-law.co.uk

### ST ANDREWS

17-21 Bell Street, St Andrews, KY16 9UR  
01334 474200  
standrewsea@thorntons-law.co.uk



@ThorntonsPropertyServices



@thorntonsproperty



@ThorntonsPS

Thorntons is a trading name of Thorntons Law LLP  
Regulated by The Law Society of Scotland